

TAP PADS FOR ADDING OPTIONAL SWIPE BAR OR SLIDER PLATE

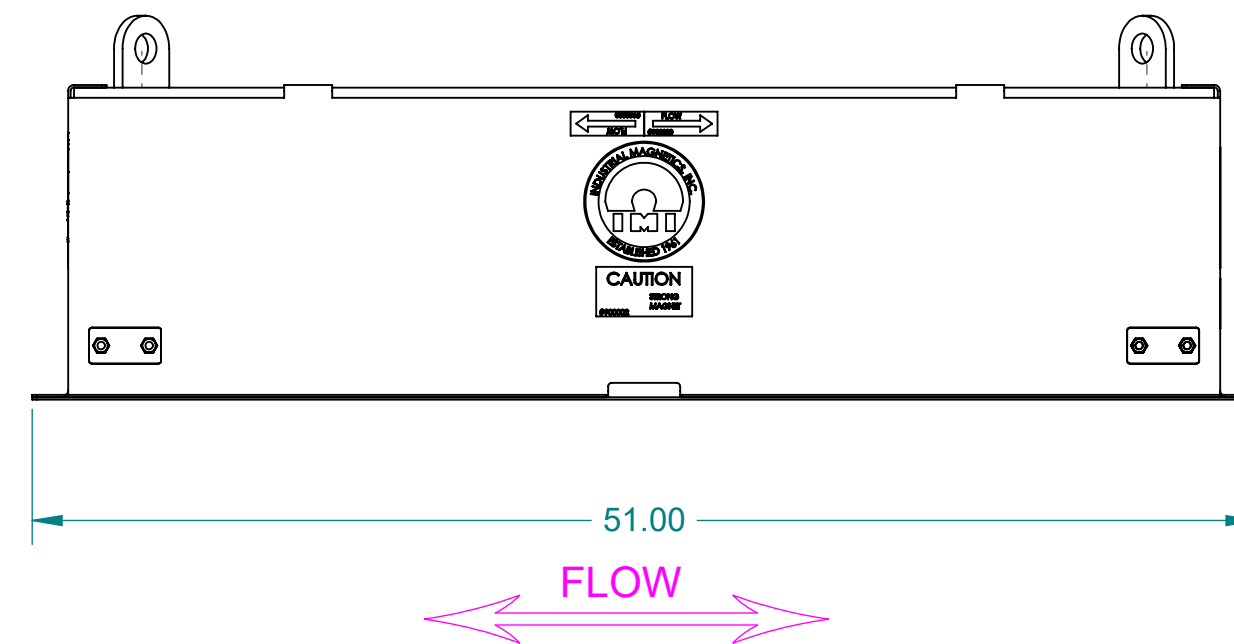
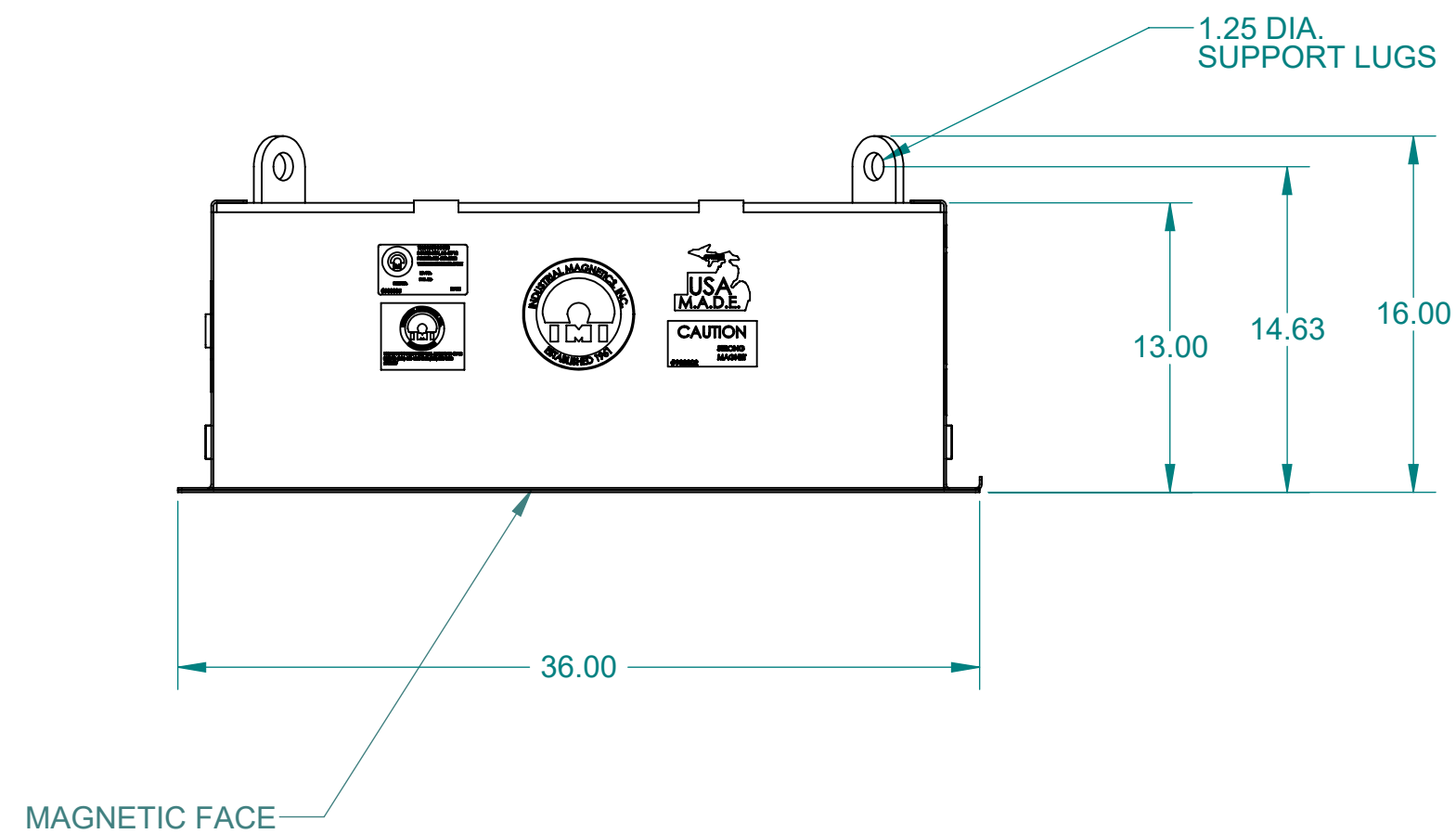

APPROXIMATE WEIGHT: 3302 LBS

ALL DIMENSIONS ARE IN INCHES EXCEPT AS NOTED.			C SIZE - SHEET 1 OF 1		
<small>This drawing and all of the elements thereof, including the design and principles of construction disclosed, is the sole and exclusive property of Industrial Magnetics, Inc. and is being submitted by Industrial Magnetics, Inc. for the limited purpose of assisting the designated recipient to evaluate the services of Industrial Magnetics, Inc. This drawing may not be used for any other purpose, nor may it be copied, reproduced, loaned, transferred, or communicated to any other person, either verbally or in writing, without the written consent of Industrial Magnetics, Inc.</small>					
TOLERANCES EXCEPT AS NOTED DECIMAL .00"=±.030" ANGULAR ±1° .000"=±.015"		RELEASED DATE DRAWN BY S.ALLAN RELEASED BY	R & D SCALE FULL DATE 9-27-12	DESCRIPTION SUSPENDED MAGNETIC SEPARATOR	
PART NO. SPMC14-36			DRAWING NO. 41921		